

1. An airplane flying over Colorado Springs at an elevation of 33,000 feet begins its descent to land at Denver, 50 miles away. If the elevation of Denver is 5000 feet, what should be the approximate slope of descent. Express as a fraction and as a percent.
2. The Americans with Disabilities Act (ADA) of 1990 states that ramps should have at least a 12 inch run for each rise of 1 inch. The post office in Drake is changing one of its entrances to accommodate a wheelchair ramp. The distance from the street to the building is 16 feet. The current sidewalk has steps up to the entrance. The entrance is 30 inches above ground level. Determine if a wheelchair ramp that meets ADA standards can be placed over the existing sidewalk. Explain why or why not.

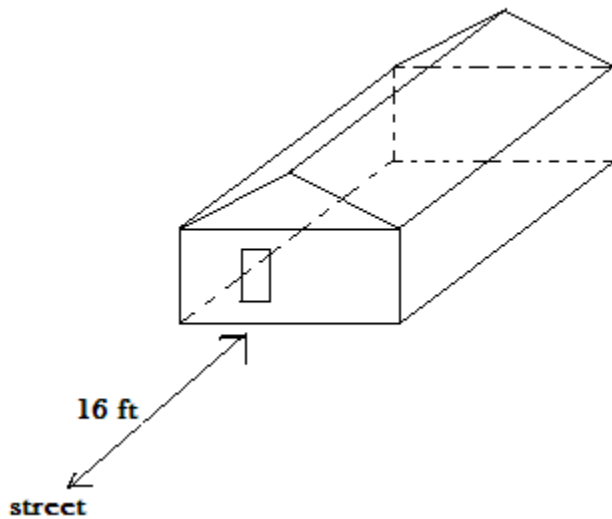

3. The pitch of a roof is the ratio of the rise to the run. The Geometry in Construction class is building a garage that is 25 feet wide. If the pitch of the roof is to be 1:3, find the rise of the roof.

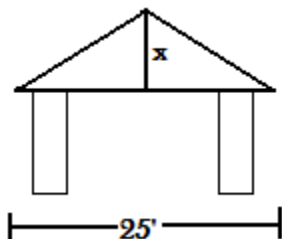

4. The I-70 grade west of Denver has a grade of 5%. The horizontal length of the roadway (run) is 5.5 miles. What is the change in elevation from the top of the grade to the bottom of the grade in **feet**?

5. Jake has 30 meters of fencing to enclose a garden plot in the shape of a rectangle.
 a) Find the dimensions of all possible gardens Jake could make using whole number sides. Put this information in the table. Find the areas of the gardens. Put all your information in the table. Of your sample garden dimensions, which give the largest area?

side	side	area

b) Suppose Jake has 75 meters of fencing. What is the largest rectangular garden he can enclose (assume the lengths do not need to be whole numbers)?

c) What is similar about the shape of the garden plots in Part a and b?

6. Maura, an architect, is commissioned to design a 144 ft² building with a concrete path around it. She makes two designs, one square and the other a circle. To reduce the cost of the path, she wants to know which building design has the shorter perimeter. Which design has the shorter perimeter?

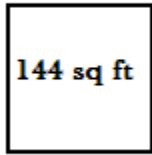

7. Describe what the five terms in the drawing below mean.

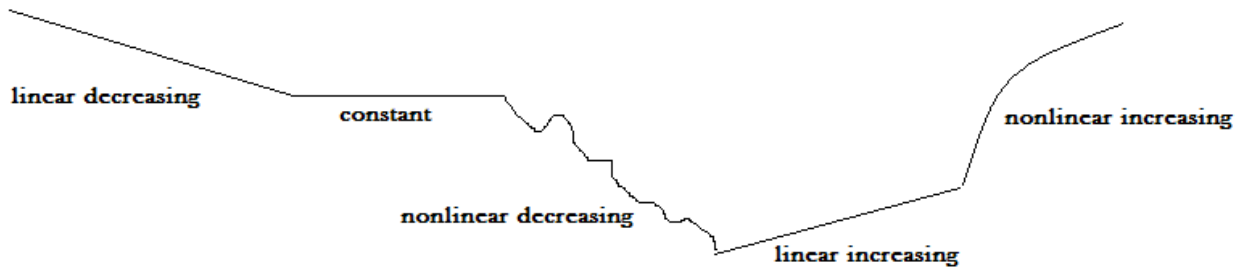

8. When developers plan new housing complexes, they must seriously consider the drainage of water from the soil. One of the duties of the grading contractor is to assure proper sloping of the soil, which, in turn, contributes to adequate drainage. The diagram below shows the measurements taken by a surveyor hired by one grading contractor. The measurements have been placed on a coordinate grid. Find the slope of the ground.

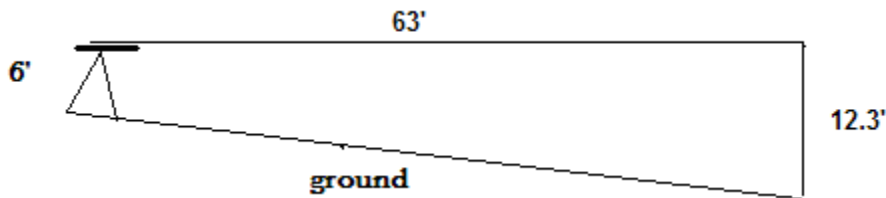

9. Convert these lengths to feet using decimals. Example $10'6'' = 10.5$ feet

a. $12' 8''$

b. $15' 9''$

c. $23' 5''$

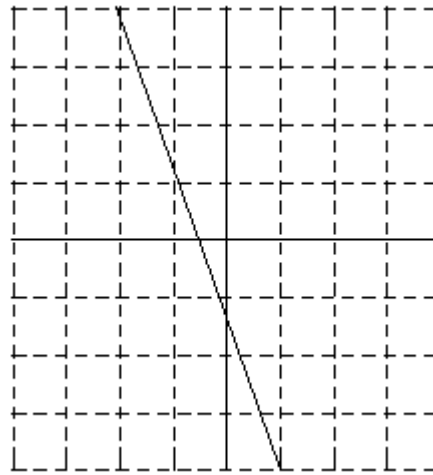
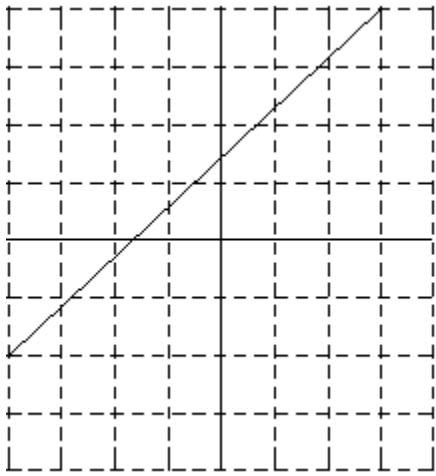

16. For the right triangle, **measure** in **centimeters** and calculate the areas of the squares on each side of the triangle. Record your data in the table below.

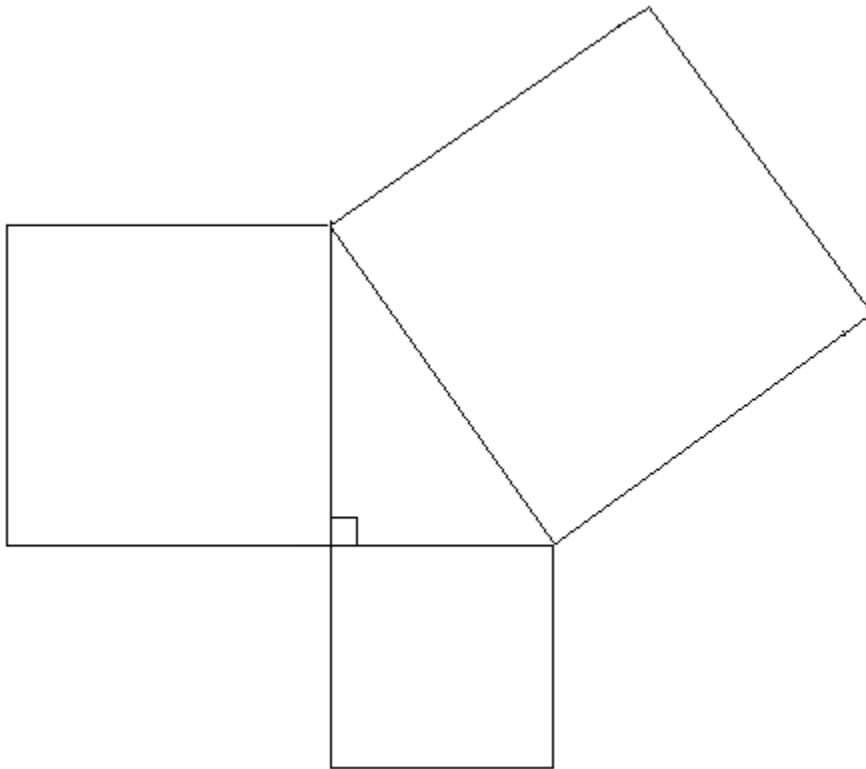

Area of square on
short side

Area of square on
middle side

Area of square on
long side

i. _____

ii. What do you notice about the area of the square on the long side when compared to the area of the other 2 squares?

17. A window measures 8 feet by 3 feet. Make a scale drawing of the window if $\frac{1}{4}$ inch represents 1 foot.

18. Some building codes require the slope of a stairway to be no steeper than 0.88, or $\frac{22}{25}$. The stairs at Evan's house measure 11 inches deep and 6 inches high. Do the stairs meet the code requirements? Explain

19. In pitched roof construction, carpenters can build the roof with rafters, one piece at a time. The rise, the run, and the rafter form a right triangle. The rise and run are the legs, and the rafter is the hypotenuse. Find the rafter length for the roof shown below. Round to the nearest tenth.

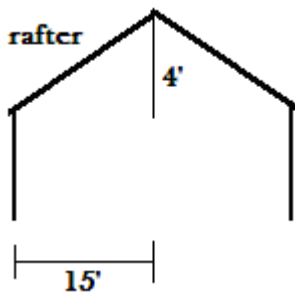

20. To make a highway accessible to more vehicles, engineers reduce its steepness, also called its **gradient**, or simply grade. A highway can be designed with switchbacks so the gradient would be small. A gradient is the inclination of a roadway to the horizontal surface (rise:run). The Eisenhower Tunnel in Colorado was completed in 1973. It is the fourth longest road tunnel in the United States. The eastern entrance of the Eisenhower Tunnel is at an elevation of 10,080 ft. The tunnel is 8941 feet long and has an upgrade of 0.895% toward the western end. What is the elevation of the western end of the tunnel?

21. The following shapes A, B, and C have the same area.

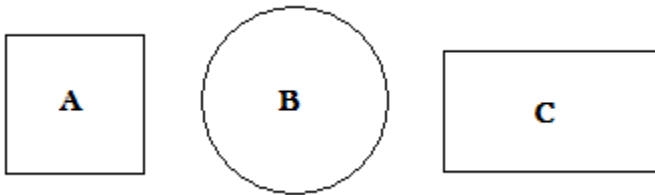

- a) Which shape has the minimum perimeter?
- b) Which shape has the maximum perimeter?

22. The dimensions of the Great Pyramid are shown in the diagram below. Some of the granite blocks used in the Great Pyramid are 25 ft. long and 4 ft thick. Each block has a mass of 49 metric tons. Egyptologists believe that the builders used inclined ramps to raise the stone blocks to these levels. As shown below, some researchers have suggested that the incline ratio (slope) of these ramps was 1:3. If the capstone (the stone on top) is 3 ft tall, how long was the ramp (hypotenuse) required to raise it? (Hint: How tall must the ramp be to get the capstone on the top of the pyramid?)

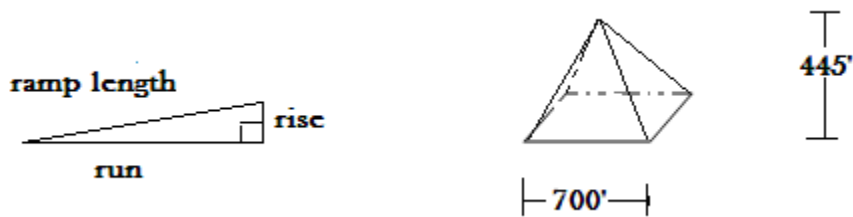

23. Ben and Sarah are building a concrete foundation for their new garage. The foundation is a square 24 feet on each side. After marking the boundaries, they decide to measure the diagonals to confirm that the corners are right angles. If the corners are right angles, how long should the diagonals be?

24. If a building site is rectangular, how long should each of the diagonals in these drawings be?

a.

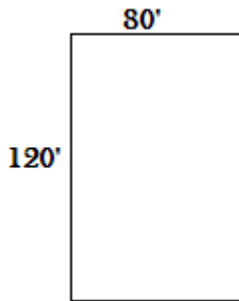

b.

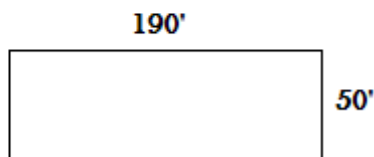

25. Using the Pythagorean Theorem determine if the measurements given could establish a rectangular shaped lot. (The angle must be a right angle)

a.

b.

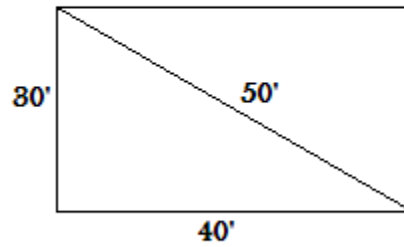
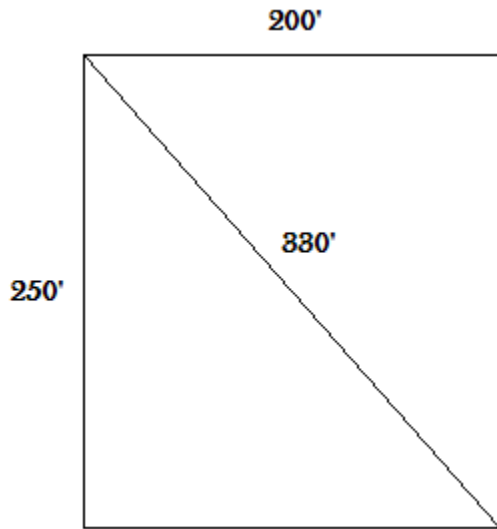

26. Materials tend to expand when heated. This expansion needs to be considered carefully when building. In the case of a railroad track, each 220 foot long rail is anchored solidly at both ends. Suppose on a very hot day a rail expands 1 inch, causing it to buckle as shown below.

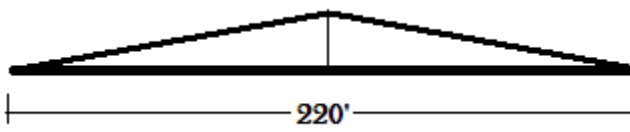

If the expansion is not controlled, how high will the track raise off of the railroad bed at the center of the 220' rail?

27. **Pythagorean triple** is a group of three whole numbers that satisfies the equation $a^2 + b^2 = c^2$, where c is the measure of the hypotenuse. Some common Pythagorean triples are listed below.

3, 4, 5

8, 15, 17

7, 24, 25

List one other Pythagorean triple.

28. A rental of construction equipment costs \$23 for cleaning plus \$56 per day to rent. Write an equation for the cost of renting of the equipment and then graph.

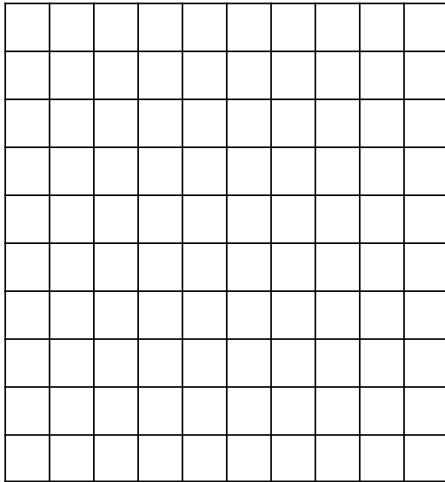

29. A trencher can dig 21 feet of trench per hour. Write an equation for the amount of trench that can be dug and then graph.

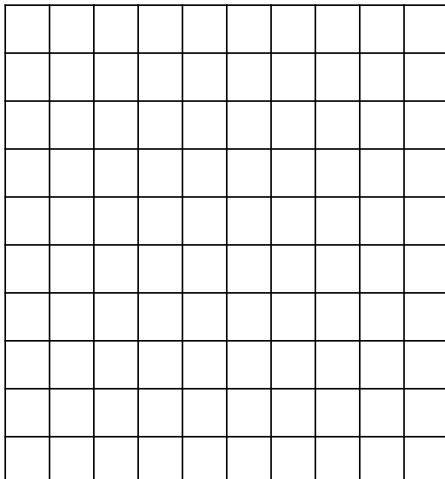

30. Graph the equations

a. $y = -3x + 1$

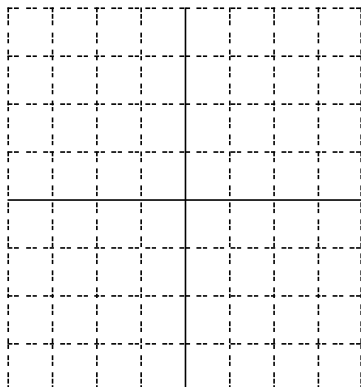

b) $y = 4x - 2$

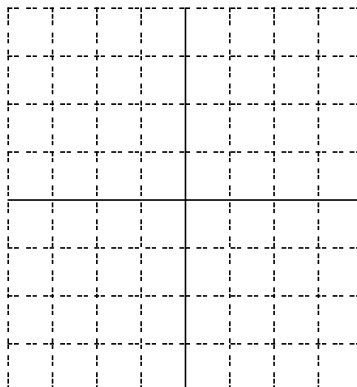

31. Solve: $3x - 2(5x + 3) = 15$

32. Simplify. Do not use decimals.

a. $\sqrt{27}$

b. $\sqrt{24}$

c. $\sqrt{50}$

d. $\sqrt{120}$

e. $\sqrt{225}$

f. $\sqrt{32}$

g. $\sqrt{20}$

h. $\sqrt{15}$

i. $4\sqrt{72}$

j. $2\sqrt{18}$

k. $3\sqrt{162}$

l. $2\sqrt{144}$

m. $5\sqrt{125}$ n. $-4\sqrt{48}$ o. $6\sqrt{4}$ p. $-3\sqrt{60}$

33. In $\triangle ACE$, $\overline{AC} \cong \overline{AE}$. If $m\angle C = 7x + 2$, and $m\angle E = 8x - 8$, what is the measure of $\angle C$ and $\angle E$? Hint: Sketch and label a triangle.

34. By law, the maximum slope of a ramp in new construction is $\frac{1}{12}$. That is, the maximum gradient of ramps or slope is 8.33% or 0.0833. The plan for the new library shows a 3 ft. height from the ground to the main entrance. How long should the ramp be?

35. Companies that manufacture ocean-going fishing boats design the boats to withstand ocean waves. They study the slopes of waves by simulating different slopes on computer grids.

- a. What is the approximate slope from point A to point B?
- b. What is the approximate slope from point C to point D?

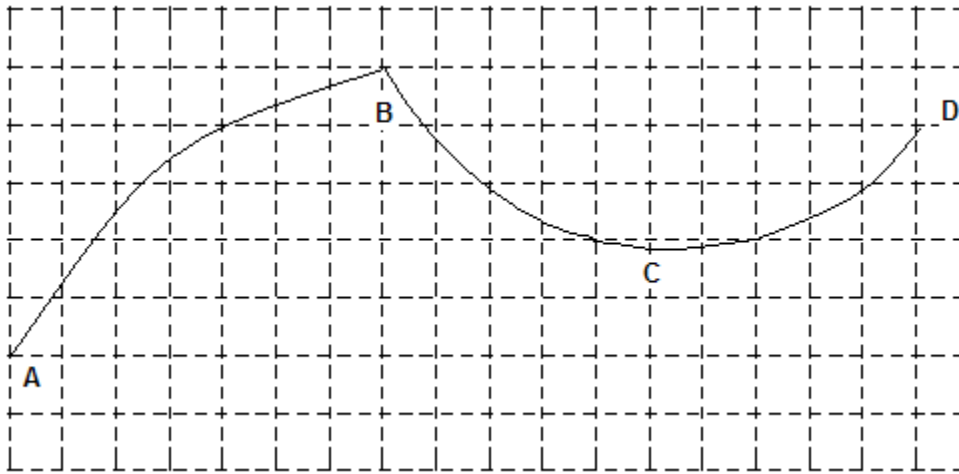

36. If a roof has a pitch of 5:12, what does the 5 represent and what does the 12 represent?

37. $C(r, -5)$ and $D(5, 3)$ are two points on a line. If the slope of the line is $\frac{2}{3}$, find the value of r .

38. $A(x, -6)$ and $B(7, -1)$ are two points on a line. If the slope of the line is $\frac{-1}{4}$, find the value of x .

Find the value of each expression.

39. $5 \bullet 3 - 4$

40. $12 - 8 \div 2$

41. $7 - (14 \div 2)$

42. $4(10 - 2) + 3$

43. $\frac{5(4 + 8)}{4}$

44. $25 - [4(5 - 3)]$

45. Find the slope of a handrail that is parallel to a wheelchair ramp. The ramp conforms to code with a 1:12 rise to run ratio.

46. An economic furnace costs \$1100 and will cost \$125 per month to operate. Write an equation for owning/operating the furnace and then graph.

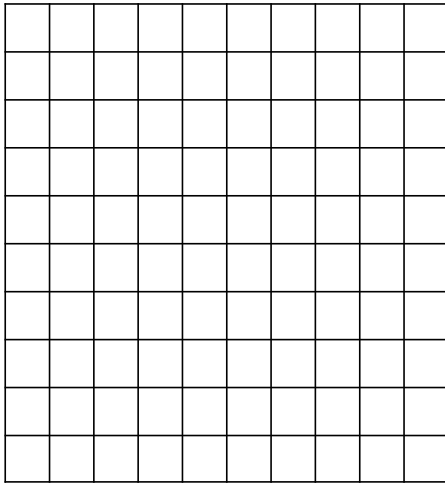

47. A deluxe furnace cost \$1850 and will cost \$90 per month to operate. Write an equation for owning/operating the furnace and then graph.

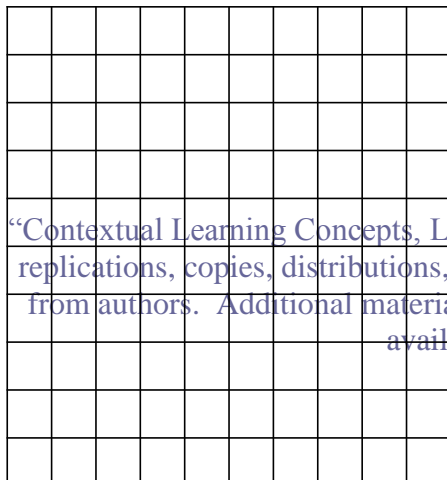

48. Solve

a) $3(2x - 6) = 4x - 3$

b) $3(2x - 1) = 4x - 3$

49. Multiply and then simplify.

a. $\sqrt{6} \cdot \sqrt{3}$ b. $\sqrt{5} \cdot \sqrt{15}$ c. $\sqrt{8} \cdot \sqrt{6}$ d. $\sqrt{2} \cdot \sqrt{24}$

e. $\sqrt{6} \cdot \sqrt{6}$ f. $\sqrt{9} \cdot \sqrt{9}$ g. $\sqrt{7} \cdot \sqrt{7}$ h. $\sqrt{23} \cdot \sqrt{23}$

i. $2\sqrt{8} \cdot 3\sqrt{10}$ j. $3\sqrt{8} \cdot 3\sqrt{5}$ k. $-4\sqrt{9} \cdot 3\sqrt{11}$ l. $-7\sqrt{15} \cdot -5\sqrt{8}$

m. $5\sqrt{8} \cdot -5\sqrt{8}$ n. $-\sqrt{16} \cdot 3\sqrt{3}$ o. $2\sqrt{10} \cdot 6\sqrt{3}$ p. $6\sqrt{15} \cdot 6\sqrt{3}$

50. A set of stairs needs to have a ratio of 7:11 rise to run. The vertical height from the first floor to the basement floor is 105 inches. How many steps?

51. Brienne is building a staircase between the first and second floors of a house, a height of 9 feet. The tread, or depth of each step must be 10 inches. The slope of the staircase cannot exceed $\frac{3}{4}$.

- a) How many steps should she plan?
- b) What is the measure of the riser, or height of each step?
52. Given each set of points, determine if \overline{JK} and \overline{LM} are parallel, perpendicular, or neither.
- a) J(-4,11), K(-6,3), L(7,7), M(6,3)
- b) J(6,9), K(4,6), L(0,8), M(3,6)
- c) J(-8,1), K(-5,-8), L(0,10), M(3,11)
53. Find the missing value if a line has the slope of 2 and it passes through the points (4, 7) and (-6, y)
54. While visiting the Colorado State Capitol, you walk up a set of steps and notice that the width of the tread (horizontal) is 12 inches and the rise (vertical) is 7 inches with each step you take. What is the slope of the steps? Express as a fraction, decimal, and percent.
55. A portion of a steel guardrail on a railroad bridge, shown below is made up of 14 congruent right triangles. The distance from point a to point b is 15 feet and the distance from point b to point c is 60 feet. What is the height (h), in feet, of the steel guardrail? Show your sub problems.

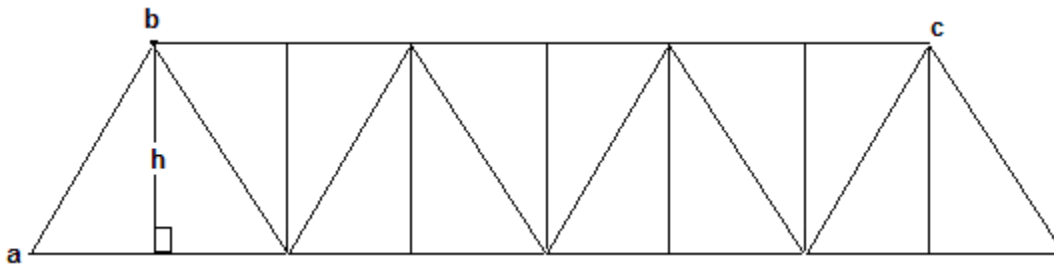

56. A pair of work boots was displayed in a shoe store with a price tag of \$60.00. No one seemed interested in buying them. The store manager decided to reduce the price of the boots by 10%. Still no one purchased the boots. The manager thought, “If the boots won’t sell at 10% off, I might as well raise the price again”. So, he raised the price by 10%. What was the cost of boots, not including any tax, after these two price adjustments?

57. Melissa drew the trapezoid shown below on a plot plan. What is the length of side a, to the nearest tenth of a centimeter?

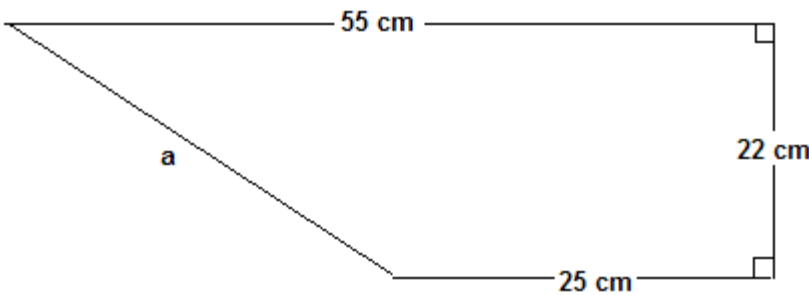

58. Mindy wants to replace her computer screen with a bigger one. She measures her current computer screen diagonally and finds the diagonal measurement to be 19 inches. She measures the width of the screen and finds it to be 12 inches. What is the approximate area of Mindy’s current computer screen (to the nearest whole square inch)?

59. Quadrilateral ABCD is shown on the grid below. What is the length, to the nearest tenth of a unit, of \overline{AB} ?

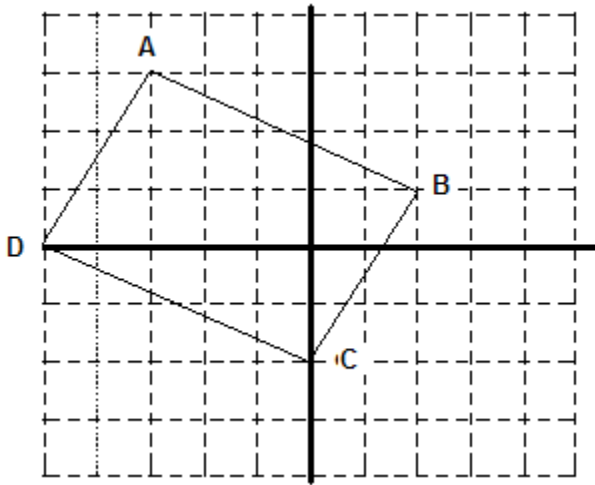

60. A lumber yard receives round logs of raw lumber for further processing. Determine the diameter of a log needed to create a 5 ft by 3 ft dimension beam.

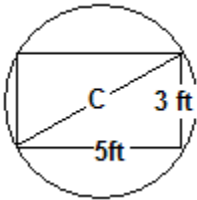

61. A saw mill needs to know the diameter of a standing tree. The logger measures the circumference with a cloth tape and discovers the circumference is 16 ft. What is the diameter?

62. At what age can someone get a driver's license in this state? Graph it on the number line below.

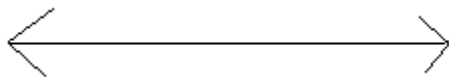

63. Find the missing angles in the plot plan shown.

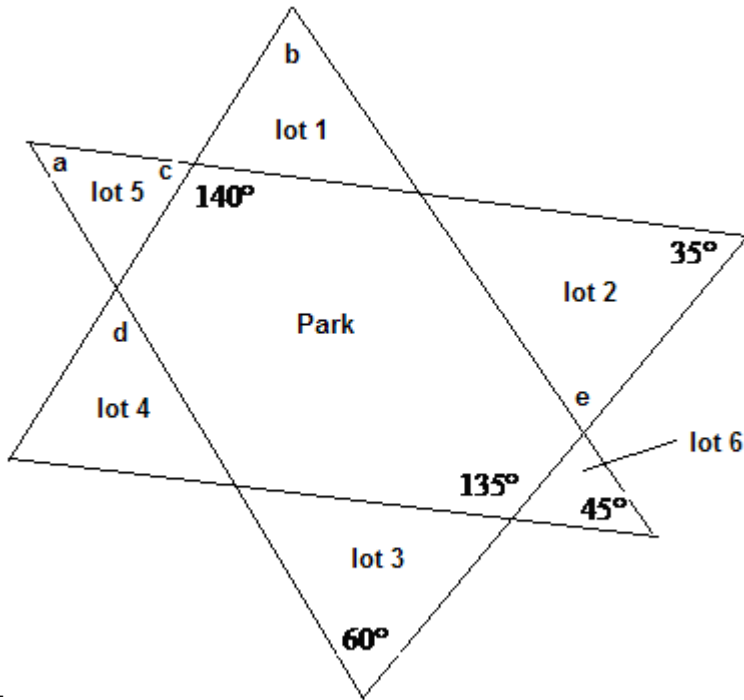

- a =
- b =
- c =
- d =
- e =

64. Joe’s Paint and Prime charges \$100 for a job plus \$20 per hour. Write an equation for pricing and then graph.

65. Susan Drywall and Patch charges \$50 for patch materials plus \$15 per hour. Write an equation for pricing and then graph.

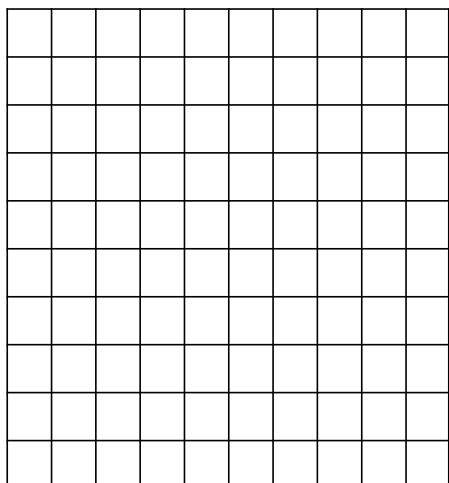

66. Solve

a) $3 - 6(2x + 6) = -5$

b) $3x - 6 = 9 - x$

67. Add/Subtract the following radicals. Express answer as a simplified radical.

a. $\sqrt{5} + 2\sqrt{5}$

b. $2\sqrt{3} - 4\sqrt{3}$

c. $5\sqrt{7} + \sqrt{7} - 6\sqrt{7}$

d. $\sqrt{8} + \sqrt{2}$

e. $\sqrt{12} + \sqrt{27}$

f. $\sqrt{125} - \sqrt{5}$

g. $\sqrt{15} + \sqrt{5}$

h. $3\sqrt{18} + 2\sqrt{2}$

i. $\sqrt{4} - \sqrt{9}$

j. $5\sqrt{72} + 2\sqrt{32}$

k. $\sqrt{8} \cdot \sqrt{3}$

l. $2\sqrt{14} \cdot 3\sqrt{7}$

68. A plot plan is shown below with the lots laid out around a central common area. Find the angles indicated.

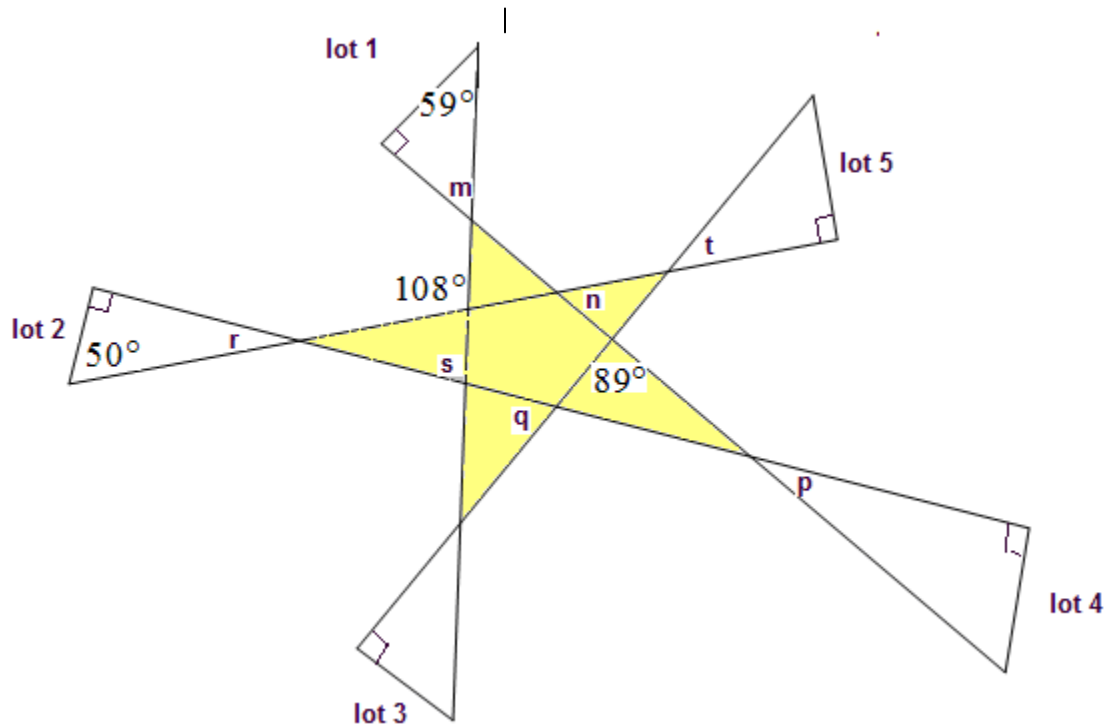

m = n = p = q = r = s = t =

Evaluate each algebraic expression for $x = -4$ and $y = 2$

69. $4(4x - y)$

70. $5x + 3y$

71. $\frac{y-2}{x}$

72. $x + 2y - 5$

73. $\frac{x+y}{3x}$

74. $4(12 - xy)$

75. A Loveland company is planning to build a new bridge over a small lake. The workers at the company must calculate the distance from point A to point B in order to build the bridge. The company workers measured the distances shown in the diagram. $\triangle ABC \sim \triangle DEC$

- a. Find the distance from point A to point B using the Pythagorean theorem.

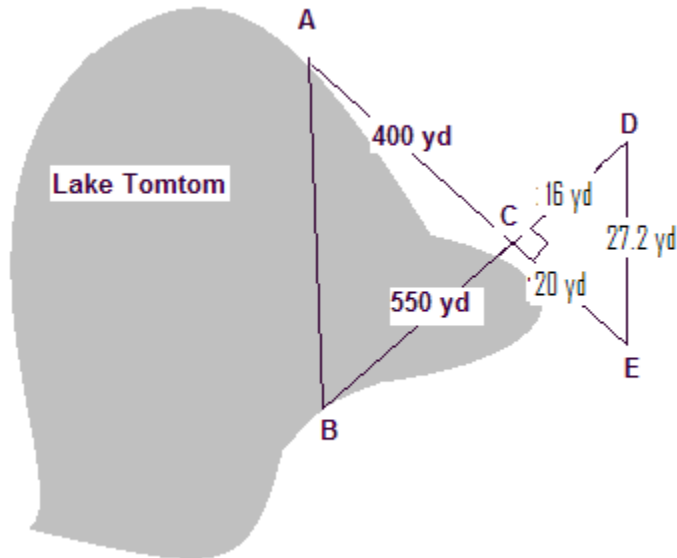

- b. Find the distance from point A to point B using similar triangles. Show the proportion

76. Find the length of a diagonal brace for a rectangular gate that is 5 feet by 4 feet. Round to the nearest tenth.

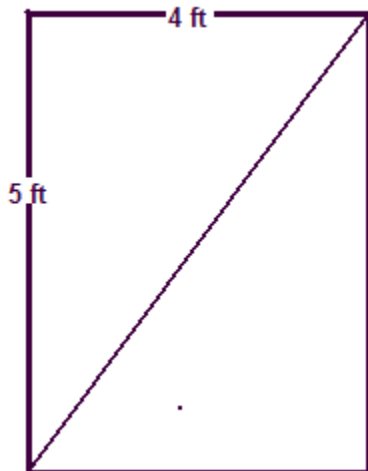

77. A carpenter was a member of a crew building a roof that is 30 feet long at the base. The roof had a pitch of 3 inches for every foot of length along the base. His task on the crew was to put in vertical supports every 16 inches along the base. He would climb up the ladder, measure 16 inches horizontally, and then measure the vertical height to the roof. He then climbed down the ladder, sawed the piece he needed, and went back up the ladder to put it in place. He wondered if there wasn't some way he could figure out how long each support would be ahead of time so he wouldn't have to climb up the ladder so many times. Explain how you can do this....and find the first 3 supports (3 shortest ones).

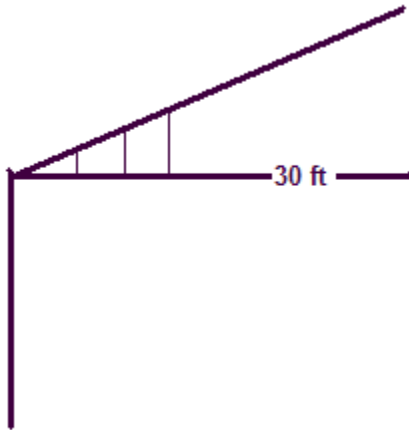

78. a) In the diagram below, what type of triangles are formed by the cables of the same height and the ground?

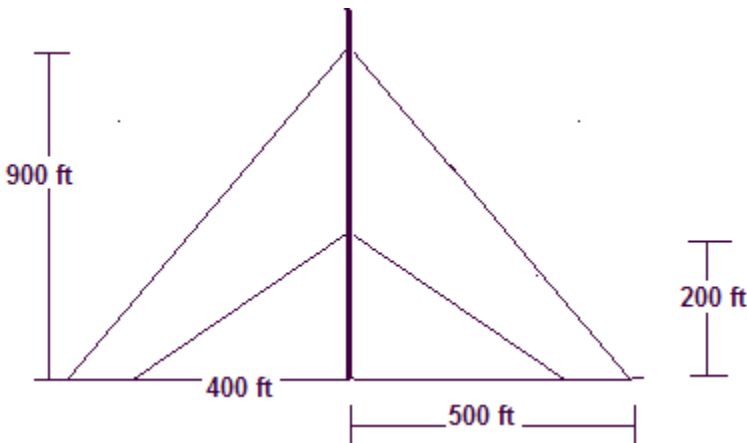

b. What is the length of the longest cable and the shortest cable?

79. Using the map of the subdivision, find the **shortest** distance between the following lot corners. (Assume that each grid unit is 0.1 mile).

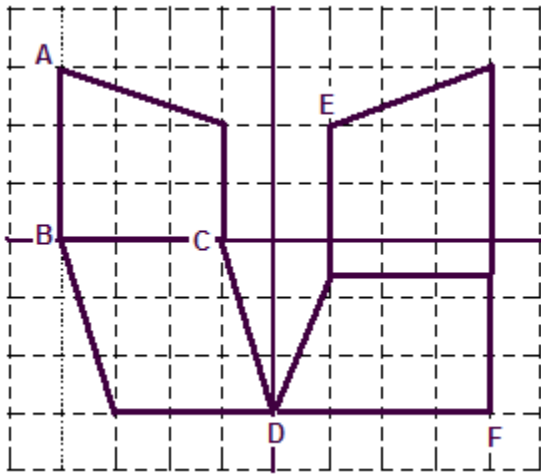

- a. CD
- b. EF
- c. AB

80. There is a relationship between a city's capacity to supply water to its citizens and the city's size. Suppose that a city has a population P (**in thousands**). Then the number of gallons per minute that are required to assure water adequacy is given by the expression below. If Loveland has a population of 55,000 people, how many gallons per minute must the city's pumping stations be able to supply?

$$1020\sqrt{P} (1 - 0.01\sqrt{P})$$

81. The Hummel family purchased twenty 8 ft sections of fencing to protect their planned garden from the family dog. They plan to use an existing wall as one of the borders. The 8 ft sections can not be cut or bent. Be careful, it is not a square.

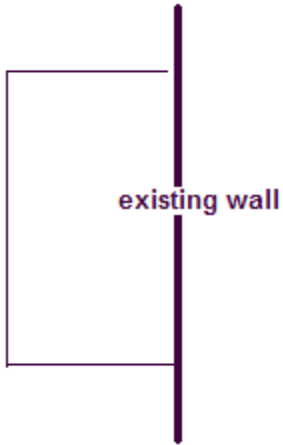

a. If needed, make a table of the dimensions and areas of gardens that can be enclosed by the 8 ft sections.

b. What is the largest garden area that can be enclosed with these sections of fence?

82. Electric by Sarah charges \$25 for a home visit plus \$60 per hour. Write an equation for pricing and then graph.

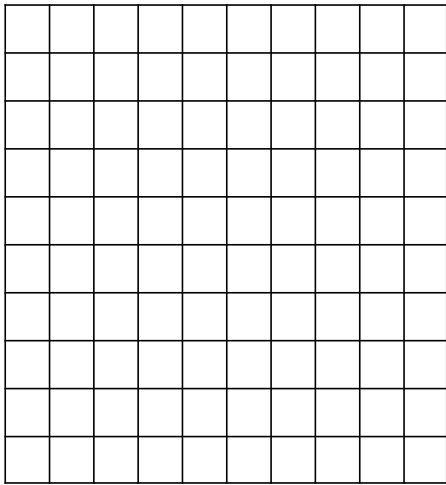

83. Find the slope of the lines passing through these points.

a) $(-50, -67)$ $(38, -78)$

b) $(0, -64)$ $(-32, 43)$

c) $(6, 80)$ $(6, 75)$

d) $(7, 76)$ $(4, 76)$

84. In order to make flat boards from a log, a miller first trims off the four sides to make a **square** beam. Then the beam is cut into flat boards. If the diameter of the original log was 16 inches, find the maximum width of the boards. Round your answer to the nearest tenth.

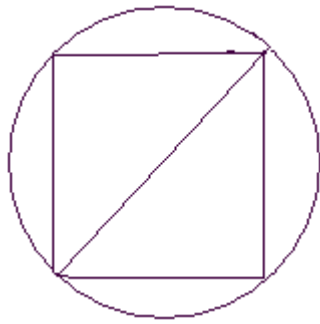

85. The strongest rectangular beam that can be cut from a circular log is one whose width is 1.15 times the radius of the log (the center of the log is the strongest). What is the width of the strongest beam that can be cut from a log 8 inches in diameter? HINT: DRAW A PICTURE

86. Scott draws an isosceles triangle with a perimeter of 30 units.

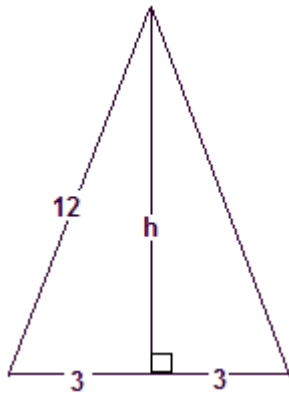

- Use the Pythagorean theorem to find h (exact value only...no decimals).
- Find the area of Scott's triangle. Round to the nearest hundredth.

87. The Colorado Department of Transportation is considering the possibility of building a tunnel through the mountain from point A to point B. Surveyors provided the map below. How long would the tunnel be. $\triangle ABC \sim \triangle EDC$

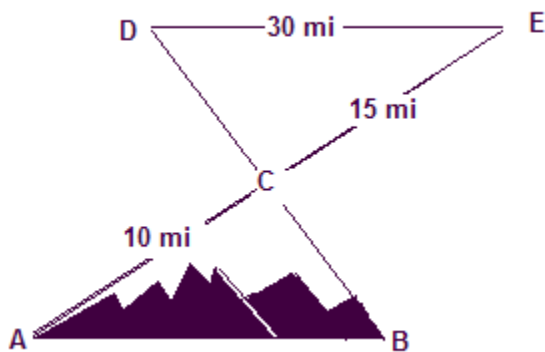

88. The following drawings are **equilateral triangles divided into 2 smaller triangles**. Each of the smaller triangles have angles with measure 30-60-90.

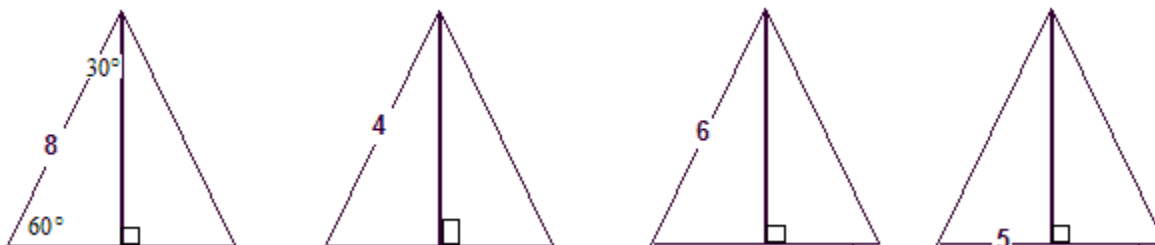

a. Complete the table below. Write your answers as a simplified radical (no decimals).

length of short leg	length of hypotenuse	length of long leg as a radical

- b. Look for patterns in the table and complete the following:
- i. Short leg =
 - ii. Long leg =
 - iii. Hypotenuse =
- c. The long leg is always opposite of what angle?
- b. The short leg is always opposite of what angle?
89. The Gothic arch is based on an equilateral triangle. Find the height of the arch. Express your answer as a simplified radical and as a decimal to the nearest tenth.

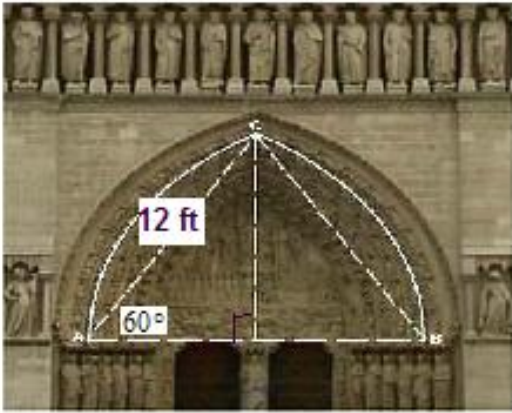

90. Truss designs from Loveland Truss are shown below. Find the missing value. Find the value as a decimal rounded to the nearest tenth, and as an exact measure.

a)

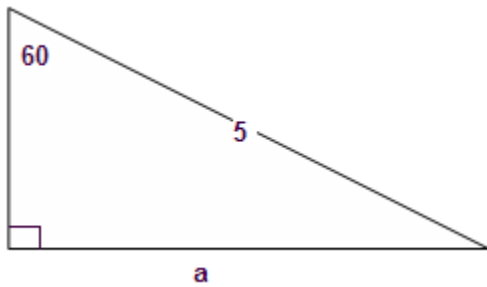

b)

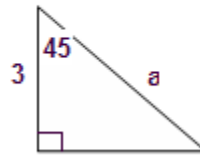

c)

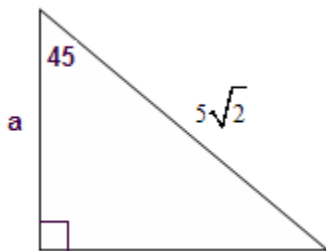

d)

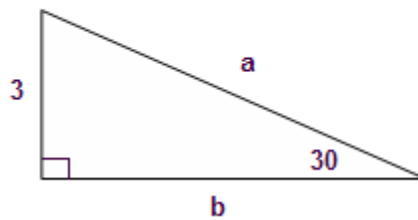

91. Below are several triangular shaped lots with a missing side in a subdivision. You need to find the missing side using exact measurements (radicals). Not drawn to scale.

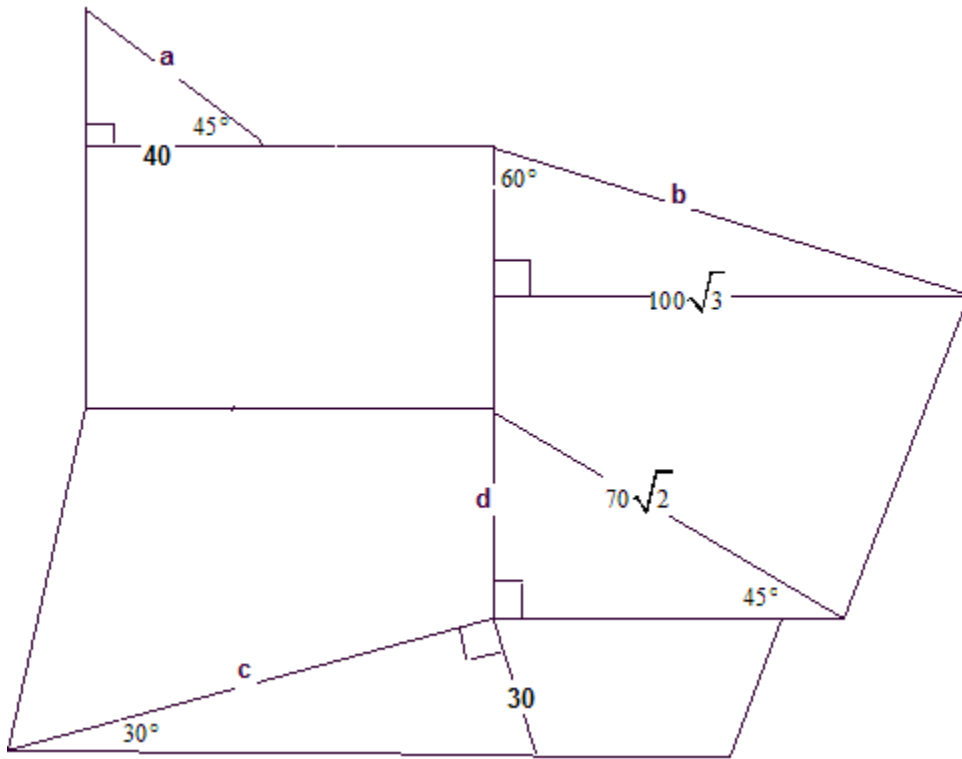

92. A civil engineer charges \$500 to look over plans plus \$200 per day in expenses. Write an equation for the charges and then graph.

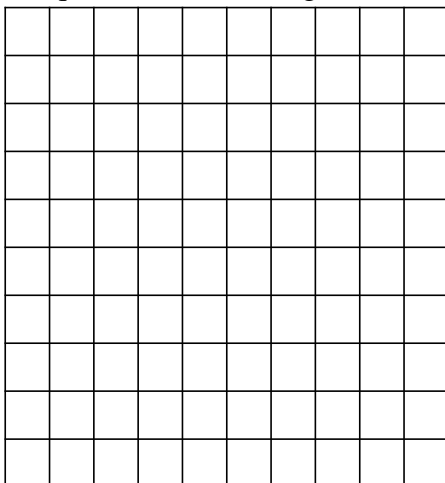

93. Jack charges \$500 to clean up a construction job site. Write an equation for the charges and then graph.

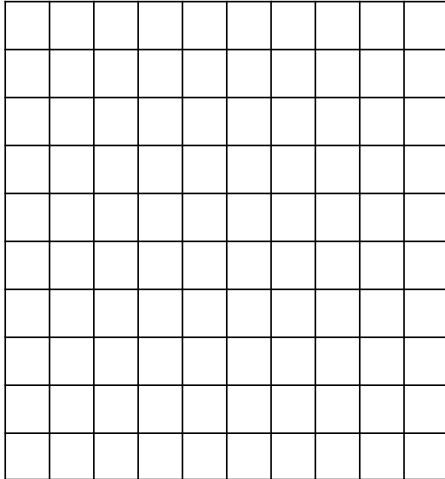

94. Find the slope used if a truss is being built using a 3:12 pitch as with this year's cabin.

95. The nailing of roof sheeting is usually perpendicular to the truss pitch for maximum strength. What would the slope of the nails be if using a 3:12 pitch

96. Solve

a) $\frac{2}{3}x - 5 = 18$

b) $\frac{3x}{5} + 9 = -19$

c) $3x + 6 = 3(x + 2)$

97. Look at the cone shown below. It is not drawn to scale. What is the volume of the cone?

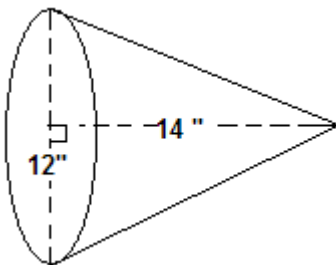

98. The summer houses of one Native American tribe were rectangular, gabled dwellings. An example is shown below. What is the volume of this house?

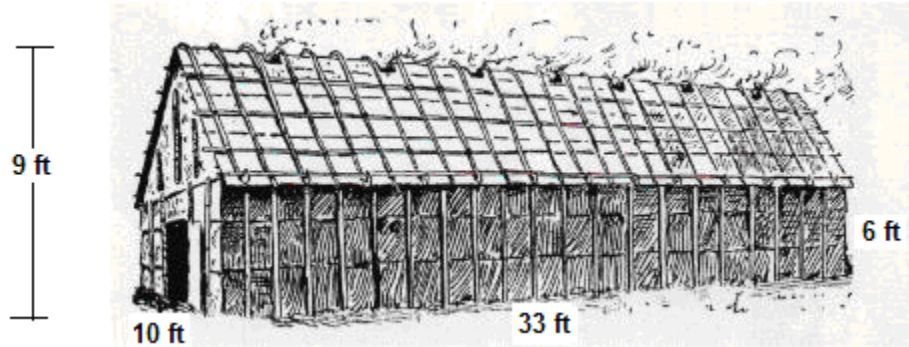

99. Mr. Felton is planning to fill his children’s new swimming pool with water. He wants to determine how long it will take to completely fill the new pool. Yesterday it took Mr. Felton 25 minutes to completely fill the old pool with water from the Felton’s outdoor faucet. How long will it take Mr. Felton to fill the new swimming pool, if the water flow from the faucet is the same as it was yesterday?

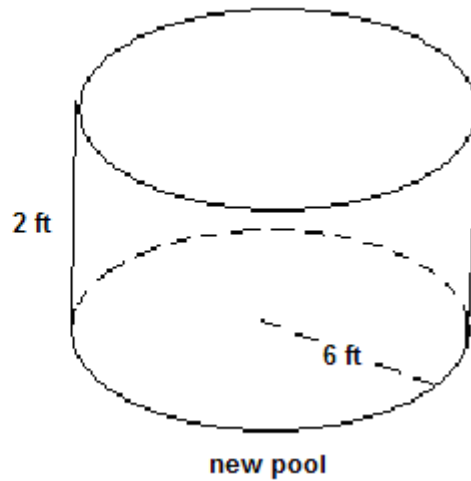
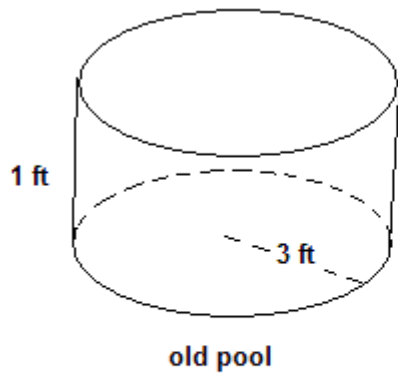

100. The air conditioning unit of a restaurant can lower the temperature inside the entire restaurant 20°F at a rate of 1000 cubic feet per minute. A diagram of the restaurant is shown below. How long, in hours or minutes, will it take to lower the temperature of the restaurant 20°F ?

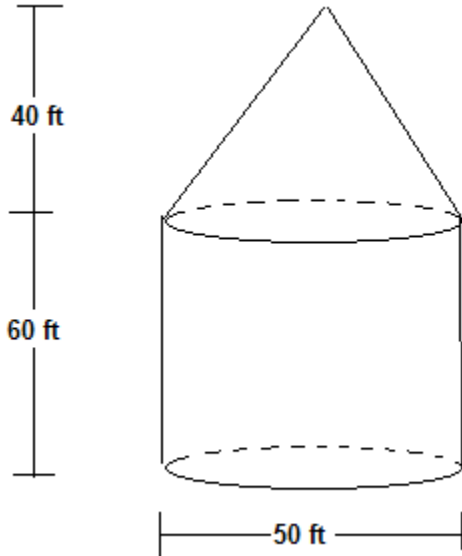

101. As shown in the following diagram, the living space in an igloo is shaped like a hemisphere. The inside radius of the igloo in the diagram is 9 feet. Determine the surface area and the volume of the igloo.



102. The Miwok tribe of California was one of several tribes which built structures with cylindrical walls and conical roofs known as roundhouses. The diagram below shows one example of a roundhouse. The floor of the roundhouse in the diagram has a diameter of 28 feet. The height of the walls is 7 feet; the total height of the building is 15 feet.

a) What is the total surface area of the roundhouse?

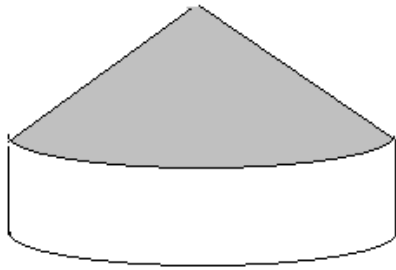

b) What is the volume?

103. The traditional house of some tribes of California was a cylindrical pit covered by a hemispherical dome. The pit in the diagram below is 3 feet deep and has a diameter of 12 feet.

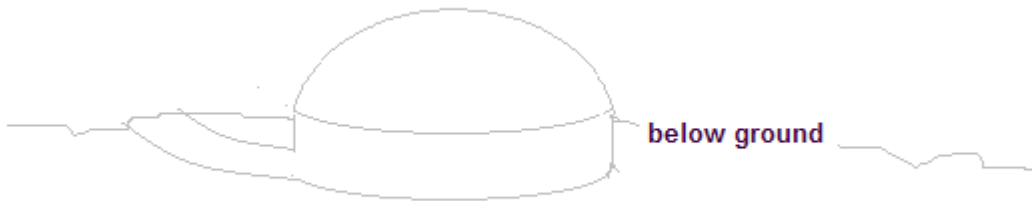

a) What is the volume of this house?

b) What is the total surface area of this house above ground?

c) What are some of the reasons the house was partially underground?

104. Tennis balls fit snugly inside a cylinder as shown. Which is greater, the volume of the three tennis balls or the volume of the space around the balls? A tennis ball has a 3 inch diameter.



105. The Transamerica Pyramid in San Francisco is 853 feet tall with a square base that is 149 feet on each side.



- a) What is its volume to the nearest thousand cubic feet?

- b) How tall would a prism-shaped building with the same square base as the Pyramid and the same volume as the Pyramid?

106. Builders use a plumb bob to find a vertical line. The plumb bob shown combines a regular hexagonal prism with a pyramid. Each side of the prism is 2 cm. The apothem is 1.7 cm. Find its volume to the nearest cubic centimeter.

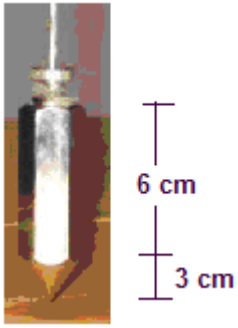

107. A teepee approximates a cone. The teepee pictured is 12 feet tall with a base diameter (circular) of 14 feet. Find the volume.



108. The Pyramid is an arena in Memphis, Tennessee. The area of the base of The Pyramid is about 360,000 square feet. The height is 321 feet. What is the volume of The Pyramid?



109. Laura is about to fill her family's aquarium, shown below, with water. Because fish, vegetation, stones, and rocks would not fit in the aquarium if she were to completely fill the aquarium with water, Laura decides that the water level should be 3.0 inches from the top of the aquarium. How many cubic inches of water will the aquarium contain once Laura gets done putting water into it?

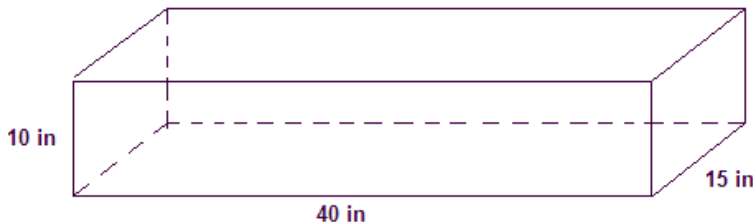

For #110-119, match each real object on the left with a geometric name on the right. You may use a geometric name more than once or not at all.

- | | |
|--------------------------------------|----------------------|
| 110. Die | a) hemisphere |
| 111. Tomb of Egyptian rulers | b) cone |
| 112. Holder for a scoop of ice cream | c) square prism |
| 113. Wedge or doorstep | d) rectangular prism |
| 114. Box of breakfast cereal | e) sphere |
| 115. Bowl | f) square pyramid |
| 116. Birthplace of a bee | g) pentagonal prism |
| 117. US military headquarters | h) triangular prism |
| 118. Pup tent | i) octagonal prism |
| 119. Moon | j) hexagonal prism |

120. Simplify

- | | | |
|-------------------|-------------------------------------|----------------------|
| a) $3 - 7(5 + 9)$ | b) $\frac{3(5 - 9)}{2 - 3 \cdot 5}$ | c) $5^3 + 2 \cdot 3$ |
|-------------------|-------------------------------------|----------------------|

121. The ramp at the Balto Burke Toy Co. outlet store was great except when it snowed and then it became slippery. The company decided to put a roof on it, 7 ft. above the ramp and parallel to it. The poles needed to hold up the roof were to be placed 4 feet apart, next to each ramp support, fastened at the bottom to the surface of the parking lot. How long should they have cut each of these poles? Hint: Similar triangles will be helpful.

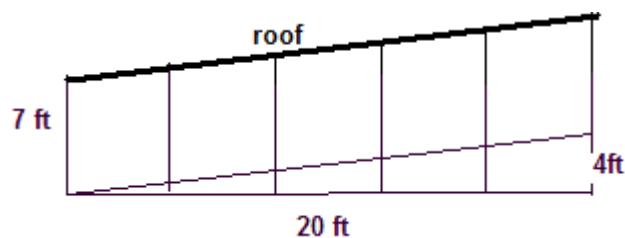

122. The rise:tread ratio is 7:11.

- a) What is the slope of the steps?
- b) What is the slope of the handrails assuming they are parallel?
- c) What is the slope of a board nailed perpendicular to the handrails?

123. In $\triangle DEF$, $\angle D \cong \angle E$. Find $m\angle F$, DF , and FE .

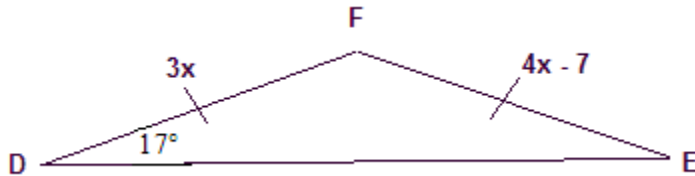

124. For each of the following 2 diagrams:
- a. Find the missing value.
 - b. Find the area of the entire roof.
 - c. Determine the number of sheets of plywood needed to cover the roof. Plywood comes in $4' \times 8'$ sheets.
 - d. Determine the number of pieces of drip edge (metal edging on all outside edges of the roof). Drip edge comes in $10'$ pieces.
 - e. Determine the number of 30 pound felt needed to cover the plywood. Felt comes in rolls that cover 216sq. ft per roll.
 - f. Determine the number of bundles of shingles needed to cover the felt. Shingles come in bundles that cover 33 sq. ft .
- i.

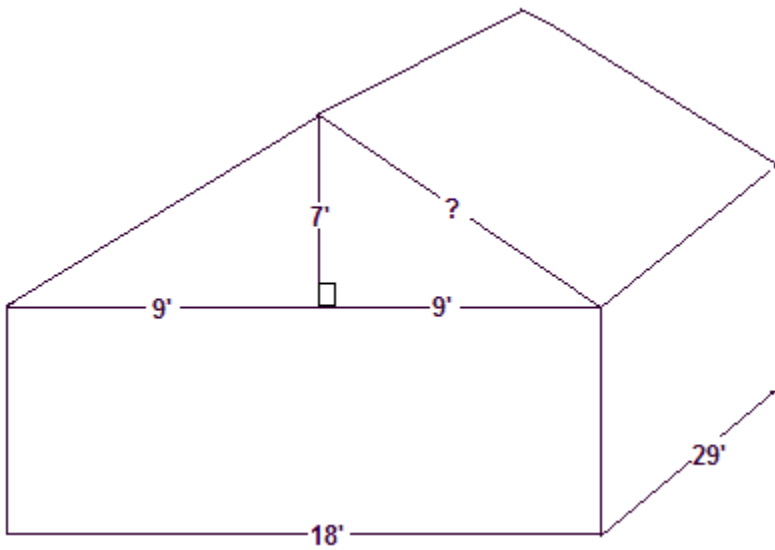

ii.

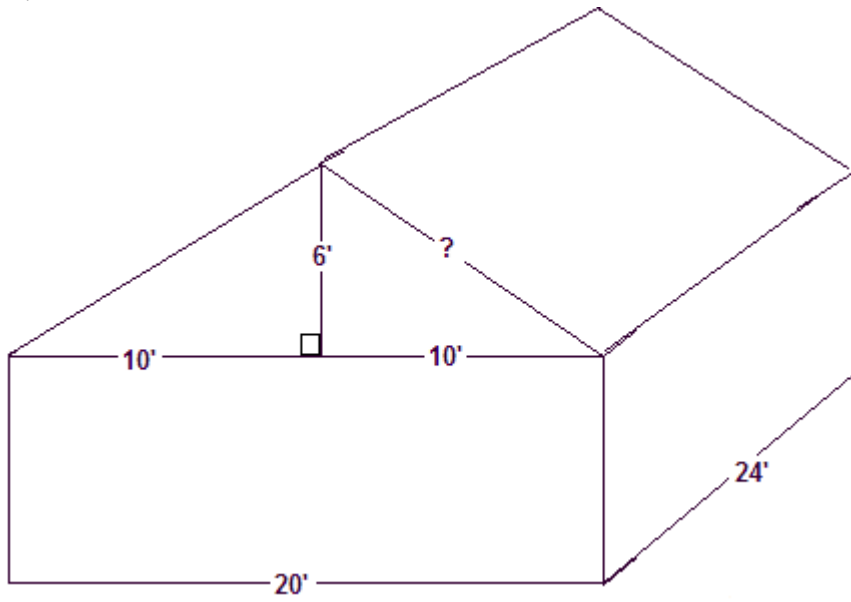

125. Hannah drew the square design shown below with each side of the outer square being 12". The midpoints of the sides of each outer square are the vertices of each inner square. That is, what looks like a midpoint is a midpoint. What is the total area of all the black regions? Explain your answer.

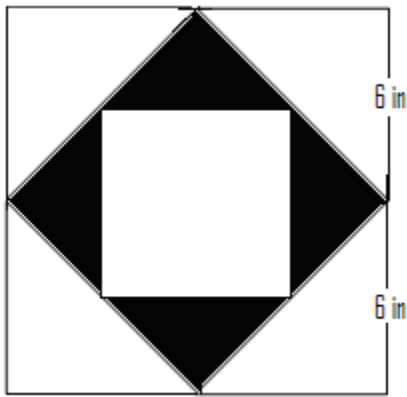

126. Routes 85 (east/west) and 392 (north/south) intersect in the center of Eaton. To reduce traffic in the center of town, government officials plan to build a road connecting at point S and point W.

- i. Suppose a person wishes to get from point S to point W, how many fewer miles will the person travel by taking the new road instead of Routes 85 and 392?

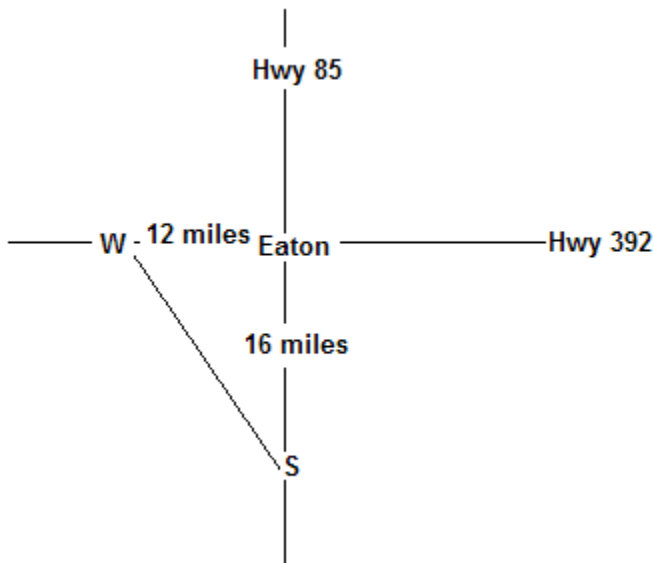

- ii. If the plans change and the new road is built from a point 14 miles south of the center of town to a point 10 miles west of the center of town, what is the length of the new road?

127. Christina is visiting Washington, D.C. She wants to know the height of the Washington Monument. The monument's shadow is 110 feet at the same time that Christina's shadow is 1 foot. Christina is 5 feet tall. Determine the height of the Washington Monument.

128. The Empire State Building in New York City is 1250 feet tall. Imagine climbing to the very top on a clear day to get a good view of the horizon. Assume the Earth is spherical and has a radius of 3963 mi. Also assume that you see a smooth horizon such as that of an ocean. Find the distance from the top of the structure to the horizon (x). 5280 ft = 1 mile

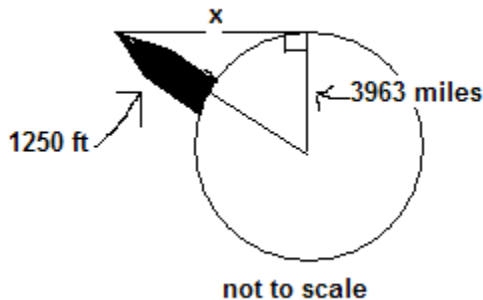

129. The square pyramid shown below has a base that measures 6 inches on each side. It has a height of 12 inches. What is the volume of the pyramid, in cubic inches?

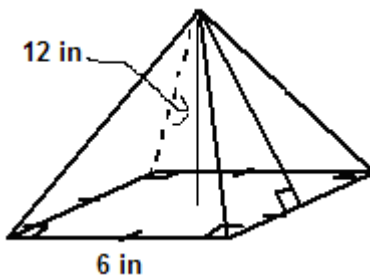

What solid would result if you spun each two-dimensional figure in #130-136 about the axis indicated? Match each two-dimensional figure on the top row with a solid on the bottom row.

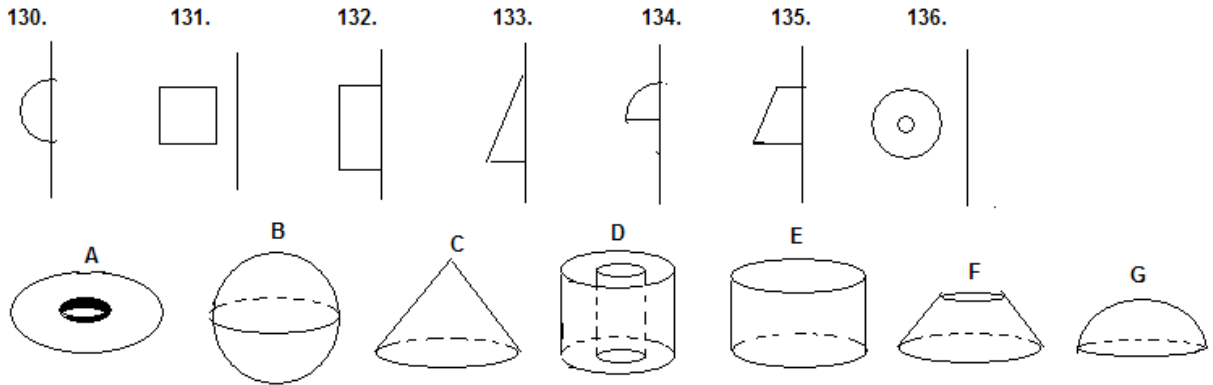

137. A modern Quonset hut has the basic shape of a half cylinder as shown below.

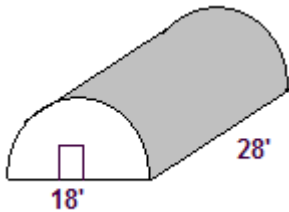

- a) What is the surface area (do not include floor)?
- b) What is the volume?

138. A 60 cm tall fish tank has a uniform cross-section. The overhead view is a regular hexagon. In the metric system, liquid volume is measured in liters, where 1 liter is 1000 cm^3 . How much water can the tank hold?

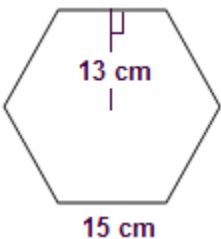

139. How many cubic yards of concrete are needed for a sidewalk 2 yards wide, 30 yards long and 1 foot thick?

140. A hot springs swimming pool is 25 feet wide.

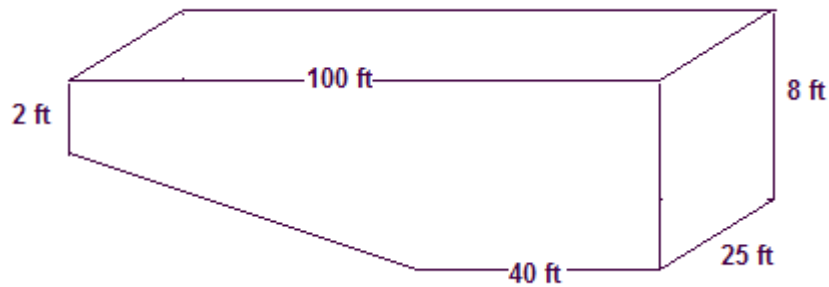

a) What is the volume of the pool?

b) A gallon of water is 231 cubic inches. How many gallons of water will the pool hold?

141. The piston in an engine moves up and down in a cylinder as shown. When it moves up, it displaces a certain volume of gas mixture. Find the volume displaced in this cylinder.

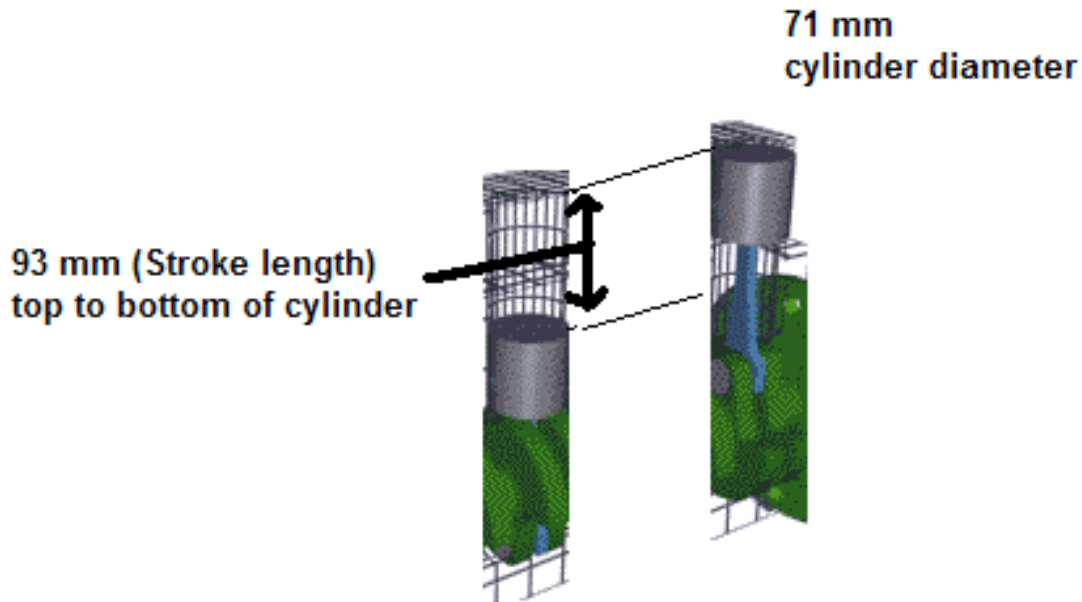

142. Consider a structure of each type with identical, rectangular bases measuring 10 feet by 12 feet. The wall heights are both 10 feet with the overall height of 15 feet.

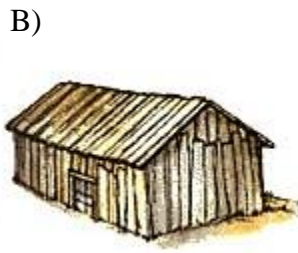
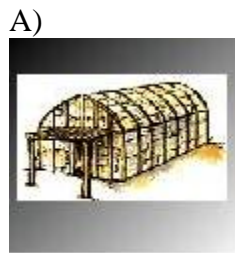

- a) Which structure has the greater surface area?
- b) Which has the greater volume?

143. Graph $y = 3$

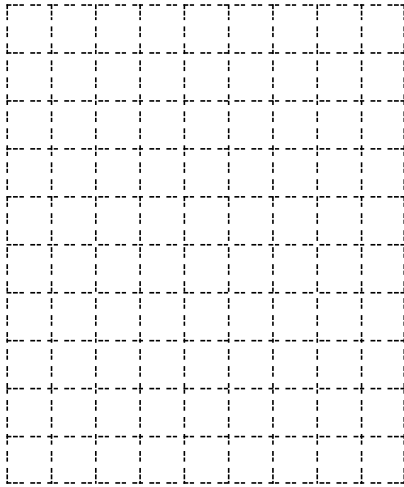

144. Graph $y = 3x + 1$ and $y = 3x - 1$ on the same graph

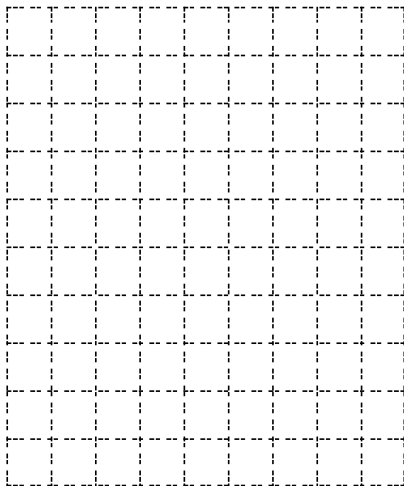

145. In #144, tell what the lines have in common.

146. Determine the volume of the toilet tank.

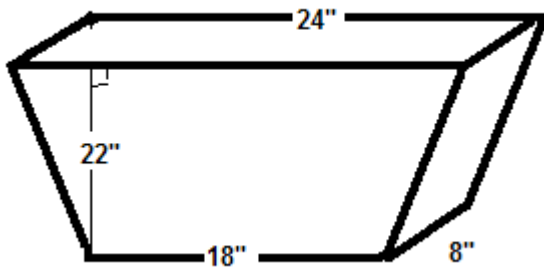

147. Suppose the artist who made the model of the tipi below used a scale of 1 in: 0.7 ft. Find the actual height and diameter. Find the volume.

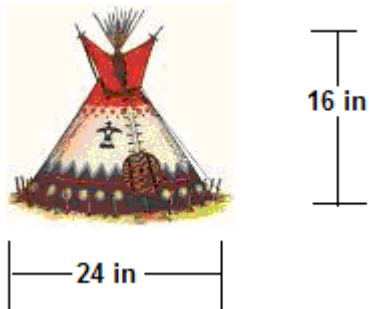

148. Rusty and Colby are farmers who specialize in raising cattle. They need to build a new feed storage silo with an estimated volume of 30,000 cubic feet for the cylinder portion. They have prepared a square piece of land, 30 feet on each side, on which to build the silo. How high would the silo need to be?

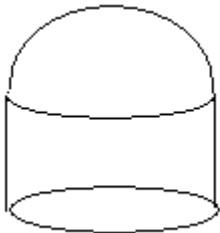

149. Order the real numbers below from least to greatest.

$$4\pi \quad \sqrt{111} \quad 1196\% \quad \frac{121}{9}$$

150. Find the volume of the pool.

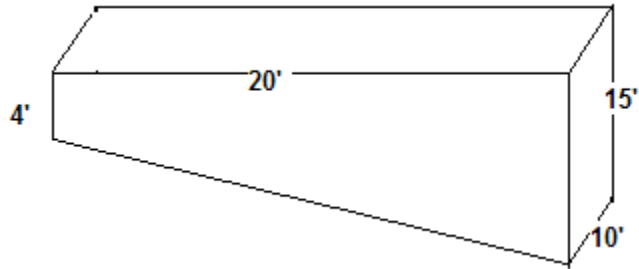

151. Why would you need to know the surface area of the pool in #150? Find the surface area.

152. Find the volume of soil that must be excavated for each rectangular part of the house. The basement must be 10' 0" deep, the crawl space must be 4' 0" deep, and the garage must be 6" deep. Your volume must be in cubic feet and **cubic yards**.

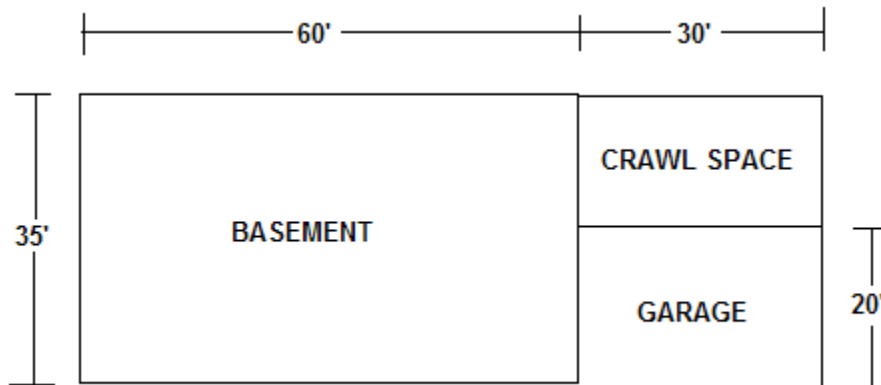

153. If a ditch was excavated, determine the volume of soil that must be removed. The ditch is 100' long and 11' deep at its deepest point. The ditch has sloping sides to ease the problem of caving in. A section view of the ditch looks like this:

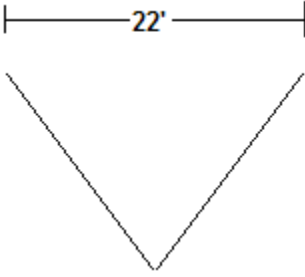

154. A company that makes baseballs packages the balls in two different clear plastic containers. One container is in the shape of a rectangular prism and encloses 6 baseballs. The other container is in the shape of a cylinder. It encloses 6 baseballs. All the baseballs measure 2.4 inches in diameter. The balls in each container are packed so that each touches another, as shown below. Which container requires less plastic to manufacture? Explain.

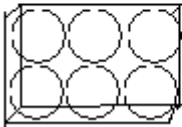

155. Estimate the amount of concrete needed in cubic feet and then convert to cubic yards
- a)

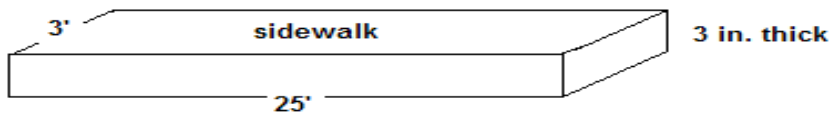

b)

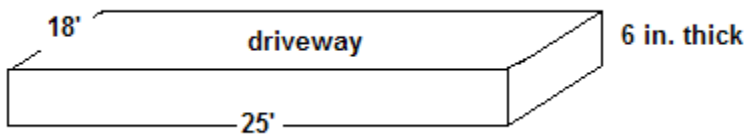

c)

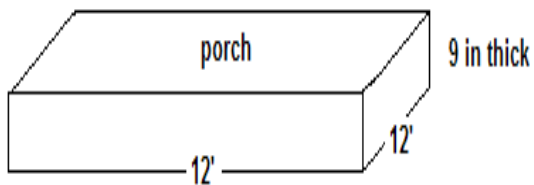

156. Simplify. No decimals

a) $\sqrt{24} + \sqrt{150}$

b) $\sqrt{32} \cdot 5\sqrt{2}$

c) $3\sqrt{54} \cdot 5\sqrt{12}$

d) $2\sqrt{120} - \sqrt{30}$

157. Find the volume of each home in cubic feet for heating and cooling needs. We do not heat or cool the attic of part b.

a)

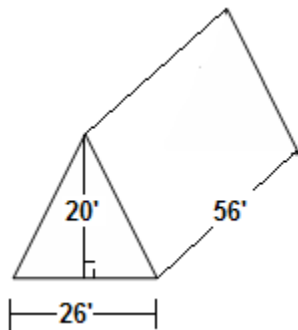

b)

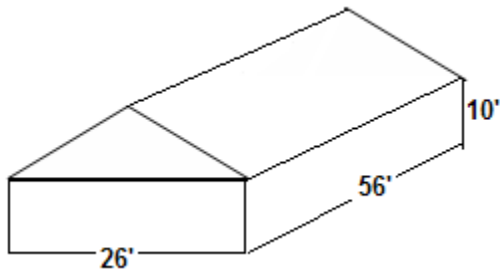

158. You need to compute the volume of concrete needed for pier supports (the whole diagram is a pier support). Figure in cubic feet and then convert to cubic yards.

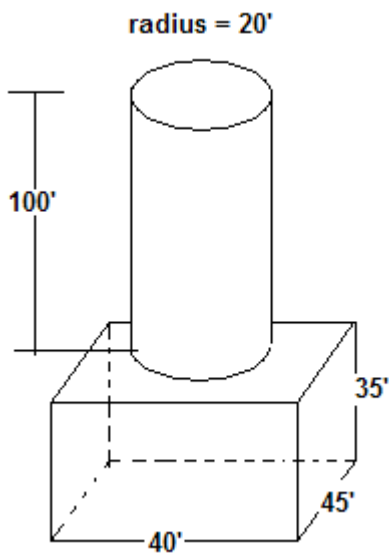

159. Find the amount of dirt that needs to be excavated for the lot below.

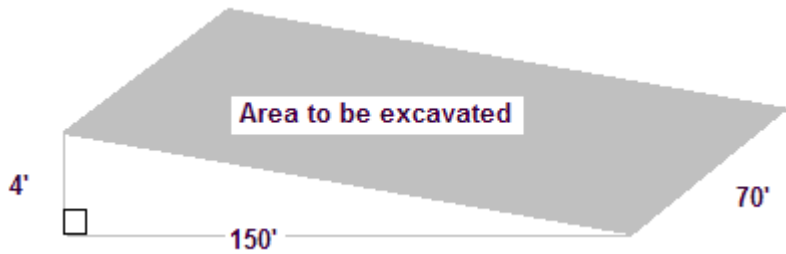

160. Simplify: $\sqrt{\frac{1}{9}}$

161. Write in scientific notation.

a) 126,000,000

b) .00126

162. Multiply to find the volume of each prism. Write the answer as an algebraic expression.

a)

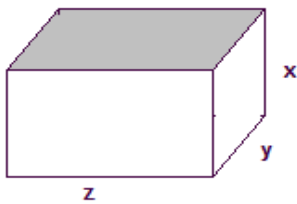

b)

